

# VIZIO

## Quick Setup Guide

VIZIO 2.1 All-in-One Soundbar SE



Lets get started.

Open for step-by-step setup instructions.

## Exclusive for VIZIO TV

Simplified setup and control for VIZIO TV owners.

### Audio Control Menu

Press the Settings button  on your VIZIO TV remote and select ALL SETTINGS > AUDIO to get started.

### VIZIO QuickFit

A proprietary mounting solution that enables elegant, tool-free installation of your soundbar with compatible VIZIO TVs.

Learn more at [vizio.com/quickfit](https://vizio.com/quickfit)

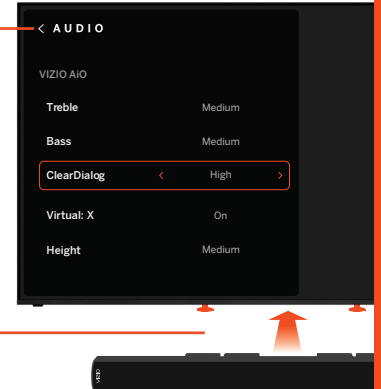

Need more help with your All-in-One SE Soundbar (SV210Y-0808)?

Click [here](#) for additional support and documentation.

## 1 Plug in and connect

Plug the soundbar into a nearby wall outlet using the included power cable. A sound will play when the soundbar is powered on and the front white LED light will turn on.



Then, connect the soundbar to the HDMI ARC or eARC port on your TV with the included HDMI cable.

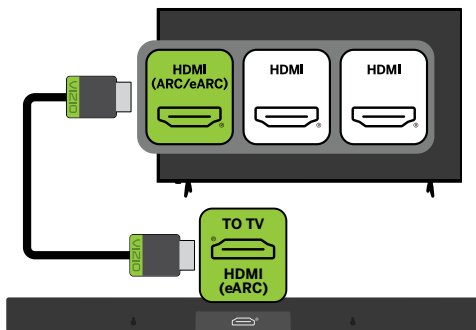

### No TV HDMI port?

Contact VIZIO support at [support.vizio.com](https://support.vizio.com) if your TV requires optical connection.

## 2 Download the VIZIO Mobile App to control your soundbar

The VIZIO mobile app and VIZIO Account are required for control of advanced soundbar functionality, settings, and to receive system updates. Click on the Apple App Store or Google Play icon below to download.



1. Stand near the soundbar and activate Bluetooth on your mobile device. After plugging in the soundbar into an active power outlet, stand near the soundbar and activate Bluetooth® on your mobile device.
2. Open the VIZIO mobile app to pair and connect to the soundbar. The app automatically recognizes your soundbar for the first hour after installation. Select *VIZIO AIO* from the list of available devices.
3. If pairing after the first hour, ensure the soundbar is powered on with a quick press of the Volume (+) button on the soundbar. Press and hold the soundbar Bluetooth (📶) button for 5 seconds and release to initiate the pairing process for up to 3 minutes. The soundbar blue LED light will blink slowly.

Once paired, you can adjust audio levels and enable Bluetooth music streaming in the app.



### No mobile device?

Your TV remote will also control soundbar volume, mute, and unmute.

## Position

Position the soundbar (A) as shown in the image below.

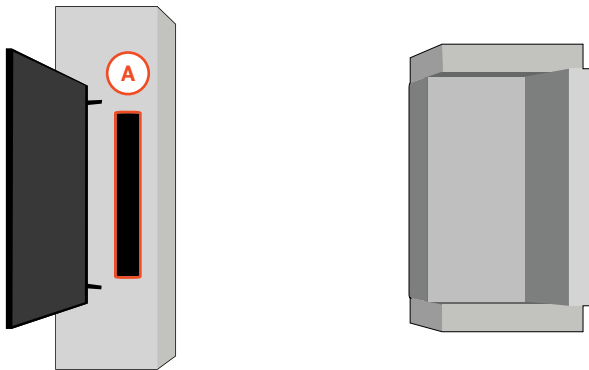

## Your sound. Your way.

Access audio controls with the VIZIO mobile app.

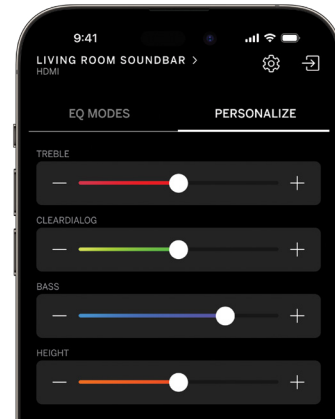

### Controlling your soundbar and TV with one remote

Use your existing TV remote to control soundbar volume and mute. If preferred, a soundbar remote control can be purchased on [vizio.com](http://vizio.com), select 'Accessories'.

## Soundbar LED light guide



**White**  
Power indicator  
Lights up full bright then dims



**Magenta**  
HDMI input  
Bright light for 3 seconds then dims to White



**Dark Blue**  
Bluetooth input



**Dark Blue Flashing**  
Bluetooth pairing mode



**Orange**  
USB input



**Green**  
Dolby Atmos® content is detected  
Bright light for 2 seconds, then dims to White



**Yellow**  
DTS:X® content is detected  
Bright light for 2 seconds, then dims to White



**Orange + Green Flashing**  
Firmware is being updated

## Get to know your soundbar

### Understanding HDMI® ARC/eARC

For highest quality audio performance, enable CEC settings on your TV and connect the included HDMI cable to your TV's HDMI ARC or HDMI eARC port. Refer to your TV manual to learn more about CEC.

### Using Bluetooth® to stream music

1. Select the soundbar device in the VIZIO mobile app, then press the Bluetooth button.
2. Press *Pair Music Device*. The blue LED will blink rapidly and a tone will play twice to indicate the soundbar is in pairing mode.
3. Go to Bluetooth settings in your mobile device, select *VIZIO AiO* and pair.
4. The blue LED will stop blinking and a confirmation tone will play when you have successfully paired.

You are all set. Now you can begin streaming your favorite music, podcasts and more.



### Don't have the VIZIO mobile app?

Quick press the Bluetooth button on the soundbar, then follow steps 3 and 4.